

## VERTICAL LIFT-TYPE CHECK VALVE

KM 9901.1 117 (Z35) FLANGED  
DN 50–400 PN 16–400

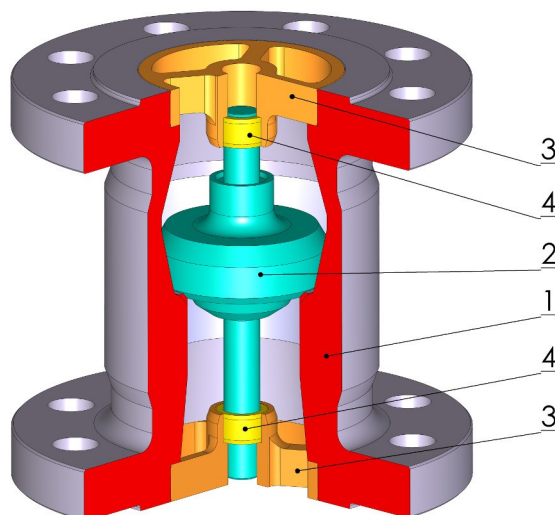
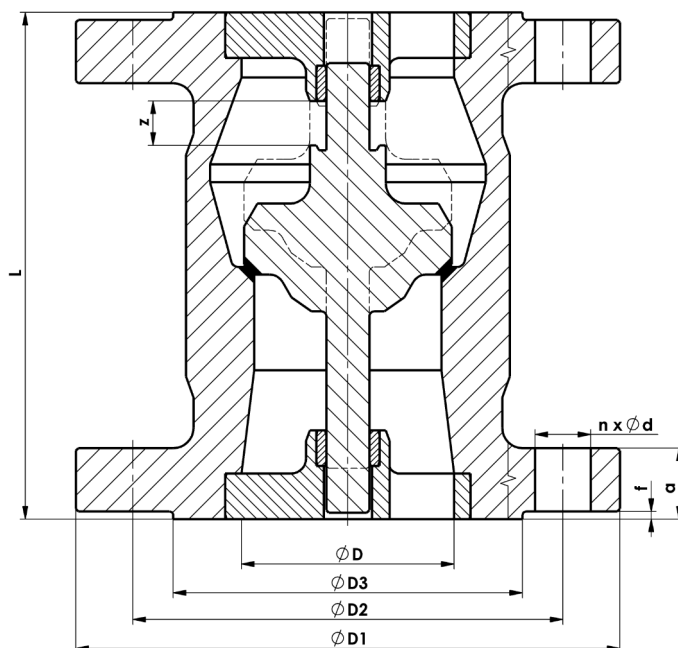

### Materials

KM 9901.1 117-X		Material			
		Stainless steel	Alloyed steel	Carbon steel	
Position	Component	X=0 For temperatures from -60 °C to +550 °C	X=3 For temperatures from -10 °C to +530 °C	X=4 For temperatures from -20 °C to +300 °C	X=4 For temperatures from -46 °C to +400 °C
1	Body	1.4541	1.5415 + seat facing 18/8 CrNi	S355J2 + seat facing 18/8 CrNi	A 350 LF2 + seat facing 18/8 CrNi
2	Disc	DN < 125 1.4541 + disc facing Stellite 6	1.4923	1.4021, ČSN 17 027	1.4541
		DN > 125 1.4541 + disc facing Stellite 6	1.5415 + disc facing 18/8 CrNi	S355J2 + disc facing 18/8 CrNi	A 350 LF2 + disc facing 18/8 CrNi
3	Guide	1.4541	1.5415	S355J2	A 350 LF2
4	Slide bearing	Nitronic 60	1.4923	1.4034, ČSN 17 029	1.4034, ČSN 17 029

Other materials upon request (P265GH, P355NL, 1.7335, etc.).  
Possible facings of seat and disc: 18/8 CrNi, 13 Cr, Stellite 6.

### Dimensions

PN 16, 25 PN 40	DN	ØD1	ØD2	ØD3	f	a	n	Ød	L	Z~
	50	165	125	102	2	20	4	18	160	*
	65	185	145	122	2	22	8	18	180	*
	80	200	160	138	2	24	8	18	200	*

\* = contact our office. Face-to-face dimensions according to table or customer's requirement.

## Dimensions

PN 16	DN	ØD1	ØD2	ØD3	f	a	n	Ød	L	Z~
	100	220	180	158	2	20	8	18	230	
	125	250	210	188	2	22	8	18	280	36
	150	285	240	212	2	22	8	22	330	*
	200	340	295	268	2	24	12	22	450	58
	250	405	355	320	2	26	12	26	480	*
	300	460	410	378	2	28	12	26	520	*
	350	520	470	438	2	30	16	26	550	*
400	580	525	490	2	32	16	30	590	*	
PN 25, 40	DN	ØD1	ØD2	ØD3	f	a	n	Ød	L	Z~
	100	235	190	162	2	24	8	22	230	28
	125	270	220	188	2	26	8	26	280	*
150	300	250	218	2	28	8	26	330	44	
PN 25	DN	ØD1	ØD2	ØD3	f	a	n	Ød	L	Z~
	200	360	310	278	2	30	12	26	450	*
	250	425	370	335	2	32	12	30	480	*
	300	485	430	395	2	34	16	30	520	*
	350	555	490	450	2	38	16	33	550	*
400	620	550	505	2	40	16	36	590	*	
PN 40	DN	ØD1	ØD2	ØD3	f	a	n	Ød	L	Z~
	200	375	320	285	2	34	12	30	450	*
	250	450	385	345	2	38	12	33	480	*
	300	515	450	410	2	42	16	33	520	*
	350	580	510	465	2	46	16	36	550	*
400	660	585	535	2	50	16	39	590	*	
PN 63	DN	ØD1	ØD2	ØD3	f	a	n	Ød	L	Z~
	50	180	135	102	2	26	4	22	160	*
	65	205	160	122	2	26	8	22	180	*
	80	215	170	138	2	28	8	22	200	22
	100	250	200	162	2	30	8	26	230	*
	125	295	240	188	2	34	8	30	280	*
	150	345	280	218	2	36	8	33	330	44
	200	415	345	285	2	42	12	36	450	52
	250	470	400	345	2	46	12	36	480	*
	300	530	460	410	2	52	16	36	520	*
	350	600	525	465	2	56	16	39	550	*
400	670	585	535	2	60	16	42	590	*	

\* = contact our office. Face-to-face dimensions according to table or customer's requirement.

## Dimensions

	DN	ØD1	ØD2	ØD3	f	a	n	Ød	L	Z~
	PN 100	50	195	145	102	2	30	4	26	160
65		220	170	122	2	34	8	26	180	17
80		230	180	138	2	36	8	26	200	*
100		265	210	162	2	40	8	30	230	*
125		315	250	188	2	40	8	33	280	*
150		355	290	218	2	44	12	33	330	*
200		430	360	285	2	52	12	36	450	58
250		505	430	345	2	60	12	39	480	*
300		585	500	410	2	68	16	42	520	*
350		655	560	465	2	74	16	48	550	*
400	715	620	535	2	78	16	48	590	*	
PN 160	50	195	145	102	3	30	4	26	180	*
	65	220	170	122	3	34	8	26	200	*
	80	230	180	138	3	36	8	26	200	19
	100	265	210	162	3	40	8	30	230	27
	125	315	250	188	3	44	8	33	300	*
	150	355	290	218	3	50	12	33	300	*
	200	430	360	285	3	60	12	36	380	50.5
	250	515	430	345	3	68	12	42	450	*
	300	585	500	410	4	78	16	42	540	*
PN 250	50	200	150	102	3	38	8	26	180	*
	65	230	180	122	3	42	8	26	200	*
	80	255	200	138	3	46	8	30	200	8.5
	100	300	235	162	3	54	8	33	230	27
	125	340	275	168	3	60	12	33	300	*
	150	390	320	218	3	68	12	36	300	43
	200	485	400	285	3	82	12	42	380	58.5
	250	585	490	345	3	100	16	48	450	*
	300	690	590	410	4	120	16	52	550	*
PN 320	50	210	160	102	3	42	8	26	180	*
	65	255	200	122	3	51	8	30	200	*
	80	275	220	138	3	55	8	30	200	*
	100	335	265	162	3	65	8	36	230	*
	125	380	310	188	3	75	12	36	300	*
	150	425	350	218	3	84	12	39	300	*
	200	525	440	285	3	103	16	42	380	*
	250	640	540	345	3	125	16	52	450	*
PN 400	50	235	180	102	3	52	8	30	230	*
	65	290	225	122	3	64	8	33	290	*
	80	305	240	138	3	68	8	33	310	*
	100	370	295	162	3	80	8	39	350	*
	125	415	340	188	3	92	12	39	400	*
	150	475	390	218	3	105	12	42	450	*
	200	585	490	285	3	130	16	48	550	*

\* = contact our office. Face-to-face dimensions according to table or customer's requirement.

## Application

Flanged vertical lift-type check valve type KM 9901.1 117 (Z 35) is unidirectional valve designed to prevent from reverse flow of the service fluid. The direction of the fluid flow is marked with an arrow on the valve's body from the bottom to the top, i. e. under the disc. In case the fluid starts flowing back, the disc closes the check valve automatically.

Vertical lift-type check valves are not designed as conventional isolating valves. If permanent tightness of the disc is required, an isolating valve shall be installed into the delivery piping. The service fluid must not contain hard and abrasive particles in form of grains or powders and its chemical composition must not form segregation deposits as this could damage the seating surfaces and bring about heavier untightness or sticking of the disc in the bearings.

The check valves are designed to be used with fluids in groups 1 and 2 according to Section 3(1)(a, b) of Decree of the Government No. 26/2003, i.e. water with the exception of potable water, non-aggressive fluids (liquids, gases, vapours, air), oil and oil products, gaseous fuels, inorganic and organic media (acc. to materials used and after an agreement with a manufacturer) and according to the directive PED 97/23/EC. The resistance of the check valve to the fluid and its temperature is limited by the chemical composition of the check valve materials. It is therefore recommended to consult the suitability for the relevant fluid with the manufacturer. Allowable service pressures are in compliance with the pressure-temperature ratings.

## Technical description

The main part of the flanged vertical lift-type check valve is a one-piece body which is made of rolled or forged steel. The body contains an inlet disc guide and an outlet disc guide with plain bearings which are pressed into the body. The pressed-in parts are secured by centre punching. The disc guides are secured in place by the counter-flanges of the piping. The seats of both the body and the disc are usually weld-deposited with austenitic steel of 18/8 CrNi type or 13 Cr or Stellite 6 – type of the weld overlay depends on the material composition of the check valve. The disc is lapped with the body seat.

## Connection to piping

Overall dimensions are shown in the tables of dimensions.

- connection according to EN 1092-1
- face-to-face dimensions of individual sizes in pressure classes PN 16, 25, 40, 63, 100, 160, 250, 320 meet the requirements of standard ČSN 13 3048, table 1
- not standardized face-to-face dimensions:
  - pressure class PN 400
  - sizes DN 50 / PN 16–250; DN 300 / PN 16–250
  - sizes DN 350, 400 / PN 16–100; DN 50–200 / PN 320

## Testing

According to EN 12 266-1 as a standard, i.e. shell strength test P10, P11, seat tightness test P12 (water pressure  $1,1 \times PN$  and air pressure 0,6 MPa), leakage rate A – zero leakage, operability test F20. Standard ČSN EN 13709 specifies that a seat leakage corresponding to leakage rate C according to ČSN EN 12266-1 is allowed in case of test P12. If required by the Customer, additional tests may be performed as well.

## Installation, service and maintenance

Vertical lift-type check valve shall be installed in vertical position. As it is an unidirectional valve, the fluid flow shall correspond to the arrow marked on the valve body.

The valve requires no special maintenance or adjustment. If the values of temperature and pressure of the fluid as specified on the valve label are adhered to, the check valve operation is fully automatic.