

THREE-WAY FLANGED BALL VALVE

with two seats, with full bore "L" or "T"

KM 9308.X-01

DN 50–150 PN 16–250

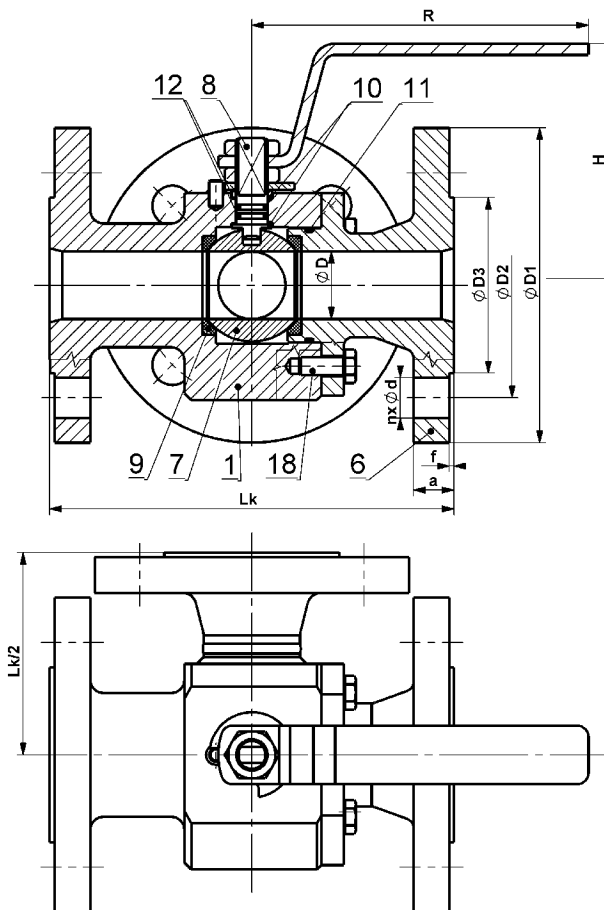

Materials

Type KM 9308.X-01		Material			
		Carbon steel		Stainless steel	
Position	Component	X=1 For common temperatures from -20°C to +200°C	X=5 For temperatures from -46°C to +200°C	X=3 For temperatures from -50°C to +200°C	X=4 For temperatures from -50°C to +200°C
1	Body	1.0577, S355J2	1.0565, A350 LF2	1.4541, A182 F321	1.4571, A182 F316
2	Cover				
7	Ball	1.4021, ČSN 17 027	1.4541, A182 F321 ČSN 17 027	1.4541, A182 F321	1.4571, A182 F316
8	Stem				
9	Seat	PTFE, PTFE+C, PEEK			
10	gasket	PTFE+C, PEEK			
11	Sealing	NBR, HNBR, EPDM, FPM, FPM+FEP			
12	Sealing	NBR, HNBR, EPDM, FPM, FPM+FEP			
18	Bolt	8.8, A2-70, A 193 B7	A2-70, A320 L7	A2-70, A193 B8	A2-70, A193 B8

Other materials upon request (P265GH, 1.4306, 1.4462 etc.).

Operating temperature range can be reduced based on selected sealing materials.

Dimensions and weights

PN 16, PN 25, 40	DN	øD	øD1	øD2	øD3	f	a	n	d	Lk	H	R	Hm / W
	50	47	165	125	102	2	20	4	18	230	130	250	19,8
	65	62	185	145	122	2	22	8	18	290	153	350	34,9
	80	76	200	160	138	2	24	8	18	310	164	350	44
PN 16	DN	øD	øD1	øD2	øD3	f	a	n	d	Lk	H	R	Hm / W
	100	95	220	180	158	2	20	8	18	350	165	450	63
	125	125	250	210	188	2	22	8	18	400			
150	150	285	240	212	2	22	8	22	480				
PN 25, 40	DN	øD	øD1	øD2	øD3	f	a	n	d	Lk	H	R	Hm / W
	100	95	235	190	162	2	24	8	22	350	165	450	66
	125*	125	270	220	188	2	26	8	26	400			
150**	150	300	250	218	2	28	8	26	480	-	-		
PN 63	DN	øD	øD1	øD2	øD3	f	a	n	d	Lk	H	R	Hm / W
	50	47	180	135	102	2	26	4	22	240			
	65	62	205	160	122	2	26	8	22	290			
	80	76	215	170	138	2	28	8	22	310			
	100*	95	250	200	162	2	30	8	26	350			
	125**	125	295	240	188	2	34	8	30	400	-	-	
150**	150	345	280	218	2	36	8	33	480	-	-		

* = gearbox recommended, ** = with gearbox only. Dimensions in [mm], weights in [kg].
Dimensions for PN 100, 160, 250 upon request.

Application

Isolating valve designed to redirect the service fluid flow. It is not designed to be used for throttling or regulating purposes. For temperatures up to +200 °C.

Suitable for:

- water, steam, gas, oil, crude oil, and other liquids and gases without mechanical impurities.

Approved for:

- fluids in groups 1 (hazardous) and 2 according to 2014/68/EU.

Characteristics

- floating ball,
- full bore,
- anti-static design,
- stem secured against release (anti-blow-out),
- ball bore form of either "L" or "T".

Operation

- hand lever,
- hand wheel with worm gear,
- pneumatic actuator,
- electric actuator.

Compliance with standards

- EN 1983,
- EN 12516-1,
- EN 1092-1,
- EN 558-1 series 1, or not standardized,
- EN ISO 5211,
- EN 13463-1 (ATEX) – II 1 GD Ex IIC TX, I M1.

Testing

- EN 12266-1, leakage rate A – zero leakage.

Flow directions

The ball valve is equipped with two seats for ball sealing, the middle connecting pipe is without a seat. The pressure fluid may be brought to the **middle connection only**, the end connections are outlet connections. The flow possibilities are shown on the schemes, other possibilities can be discussed by phone.

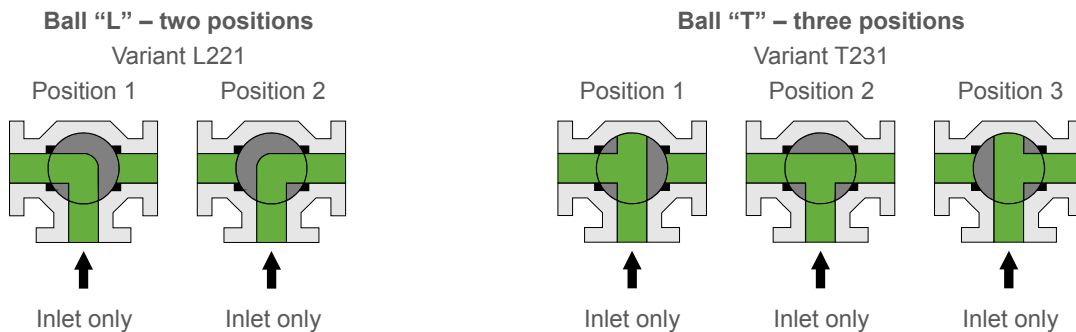

Optional accessories, adjustments and services

- different face-to-face dimensions or end combinations
- adaptation of face form (Groove, Tongue, Spigot, Recess, O-ring groove, RTJ)
- connection for actuator according to ISO 5211
- fire-safe design – fire resistance in accordance with EN ISO 10497 (API 607)
- heating jacket – for keeping the fluid liquid
- lockable handle with a padlock – for locking opened / closed position of the valve
- extended stem – e.g. for the reason of insulation of the valve and pipeline
- limit switches
- documentation according to EN 10204 3.1 or 3.2
- special adjustments according to customer requests
- design according to standard NACE MR 0175 or ISO 15156
- design according to API standards.

Type designation

